

Specifications: Models 747630E Series, Wedge-Wedge Wire Bonders, Manual X-Y-Z

Models of this series bond aluminum or gold wires ranging from 0.0007 in. to 0.002 in. diameter or ribbons up to 0.0005 X 0.010 in. section, by the wedge-wedge technique using ultrasonic energy to attach aluminum at room temperature and adding work piece heat for gold. Wire is clamped and threaded diagonally under the bonding wedge; wire or ribbon is clamped and fed vertically down through the tool. Both of these methods allow independent feeding action but require front-to-back bonding direction. The bonding tool is guided manually by the operator using hand/eye reference to bond targets and elevations.

Embodied in this series is a new and unique West-Bond three-axis micromanipulator in which the entire mechanism is arrayed above the work plane, so that there is now no limit to the size of a work piece. Each of the X, Y, and Z axes is straight-line and purely orthogonal, and each can be braked pneumatically on signal. In this application, all axes are braked during the ultrasonic bond time to aid operator control. Dual counterweights balance the pantograph arm and the tool support individually, and they are complemented by an adjustable spring to counterbalance different tool assemblies. The resulting feel and balance are the best of all the model series.

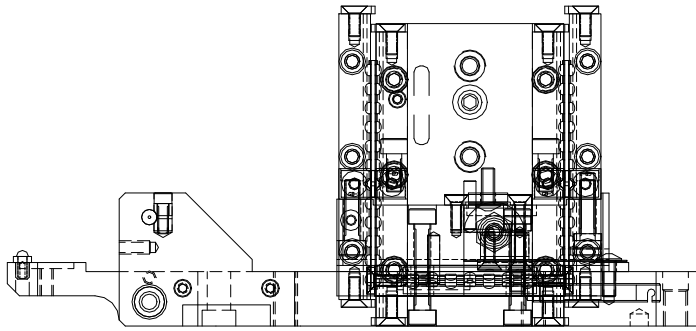

It should be understood that the pneumatic axis brakes cannot prevent deliberate efforts at movement, but that they are a significant aid in maintaining correct tool to work contact during bonding.

Range of movement of the tool by manipulator control is 0.5625 in. vertically and 0.6250 in. in horizontal directions with an 8/1 ratio of mechanical advantage.

The new forward-pivot tool assemblies of this series are built around K~Sine Transducer, Model No. 34-W, operated at 110 KHz. It is driven by K~Sine Part No. 10344 Ultrasonic Power Supply, three Watts, dual channel, with power and time set as program values. This transducer

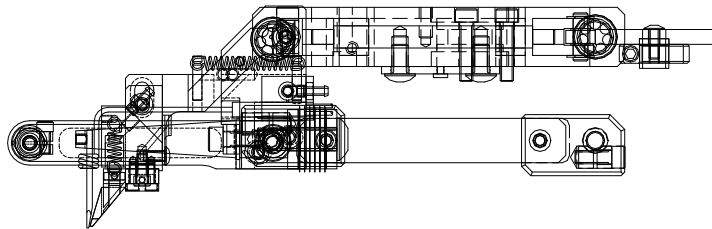

uses a bond tool of 0.828125" length dropped 0.750" below center. Vertical clearance is a full 0.46875" everywhere under these tool heads and all other mechanism except for wire presentation at 45° for angled feed. Wire Clamps are air-opened and spring-closed, and have self-contained closure pivots. A separate pivot about

an axis located to serve both overhead and angled feed generates the clamp motions along their lines of feed action. To change between angled feed and overhead feed, it is necessary only to exchange the small clamp assemblies and to change the wire drag means. Alignment of clamps to the tool is facilitated by individual adjustments along three axes. Actuation of all clamp motion is by the same spiral cam of an inboard motor and is transferred through the pivots of the four-bar linkage. Appropriate clamp motion settings for each method are configured in software and are

retained in non-volatile memory. Motions toward the tool are spring-driven, while the more powerful motor drives away from the tool – to ease concerns during set-up.

Rigid bearing mounts, rather than taper loading, fix the strut bar of this assembly so that any required bond force can be applied. The standard set of force springs generates 15 to 150 grams, and together with the work-sensing firing switch, is built into the four-bar linkage. A dual force mechanism, operated pneumatically, acts to change between two pre-set force values, and either high or low force may be programmed for any bond. Radiant tool heat with panel mounted, constant current control is included.

A high-resolution optical encoder is fitted to the Z-axis to provide position measurement of each bond elevation and then to initiate clamp re-closing to control wire loop arch consistency. This encoder enables a second function unique to West-Bond's "E" Series: Upon touchdown, contact is sensed by opening of firing switch contacts but initiation of ultrasonic energy, and the setting of the axis brakes, is withheld until the control is moved downward an additional amount sufficient to follow the deformation of the wire during bonding.

Control of machine logic, motor motions, and Ultrasonic energy is programmed to and executed by West-Bond Part No 8100 CPU containing a Motorola 68000 microprocessor and 256 KB of nonvolatile RAM. All machine configuration constants and bond settings are programmable at the machine panel, prompted by a series of "screens" displayed on a 4-line 40-character LCD. Thirty separate buffers of bond settings for a wire type can be entered and selected during bonding by a selector switch. Each wire type can have approximately 21 stitch bonds, each with its own settings of ultrasonic power and time. All programmed values are displayed during bonding. At "home", various options are enabled.

The mechanism of this series was designed to mount above a customer's work handling system, to be confined entirely above the work plane, and so not to have any base or work platform. In this configuration, models of this series are designated as "7~~~EX". For use as stand-alone complete bonding machines, the mechanism will be completed with a plain base and the bolt-on work platform and will be designated as "7~~~E". An adjustable height platform, Feature -79, is available as an option for "E" machines.

In either the "E" or the "EX" configurations, an optional control arm is included to move the single control point five inches vertically from its normal position near the machine base to a new location above the work plane. When the high control location is used, the customer must provide a suitable operator's forearm rest. This is essential both for the operator's safety and comfort, and to provide a stable platform from which to direct control motions with the accuracy required for wire bonding.

Mounting points for the "EX" version of this mechanism are provided at two foot locations at the work plane elevation 5.000 in. above table surface, approximately 22.000 in. apart, and 10.000 in. to the rear of the work point. Alternately, the mechanism can be mounted at a single location at the rear of the main plate, 0.3750 in. above the work plane; however, preferably in combination with one of the two side mounts.

Protection against Electrostatic Discharge is implemented by finishing exposed tool assemblies and other moving parts by Electro less Nickel plating, which is conductive; and all exposed painted parts with a powder-coated paint that is dissipative.

Definitions of complete stand-alone Models of this Series:

- **Model No. 747630E.** This machine with single wedge bond tool head, Assy No. 9004, with angled clamp Assy No 9048 and overhead clamp Assy No 9049, for bonding by either wedge method.
- **Model No. 747630EX.** This machine, specified as Model 7476E, except without base.
- **Model No. 747730E.** This machine with two bond tool heads, Assy No 9004 with the two clamp assemblies for wedge bonding as above, and with tool head Assy No 9044 for ball bonding, all convertible.
- **Model No. 747730EX.** This machine specified as Model 747677E, except without base.

Features available for both "E" and "EX" Models of this Series:

- **Feature No. 70.** Adjustable height work station with a rotary platform to rotate work about the center of tool X-Y range. Assembly No. 8965. Recommended to pre-align bonds front to back. Not for "EX models.
- **Feature No. 79.** Adjustable height work platform. Assembly No. 8965. Not for "EX" models.

The microscope recommended for this model is either the Olympus SZ51-60E with the "Luxuray" LED illuminator #10265. Neither microscope nor illuminator is included. One recommended bonding tool is included.

All work holders are priced separately, and should be ordered separately. A universal unheated work holder, capable of holding most common substrate devices between a pivoted clamp lever and adjustable backstops, is maintained in stock and is available for delivery in the same time span as the machine. This workstation modified for screw-adjustable height is also available from stock. Quite a large number of previously designed special work holders, both heated and unheated, are available but are not stocked, and cannot be promised for delivery with the machine. These should preferably be on an order separate from the machine order, but if not, the machine order must state that partial deliveries are allowed. Work holders for new work pieces requiring custom design and fabrication will be quoted upon receipt of drawings and samples: These must be ordered on separate purchase orders.

Compressed air, regulated to 50 psig, is required. Connection is via 1/4-inch tubing.

Electrical service required is 50-60 Hz, single phase, either 115 VAC or 230 VAC, selected automatically. A fuse and three-prong power cord connector are provided for 115 VAC: For 230 VAC, these must be changed to conform to local requirements. The electrical power supply, Part No 8850, is packaged in a separate enclosure 8.75"wide x 8.00" deep x 3.00" high.

"E" Series machine size is 24.0" wide x 21.250" deep x 11.625" high, exclusive of microscope, or 15.00" in height to scope eyepieces. Weight is 60 lb. uncrated, or 140 lb. accessorized and crated.

"EX" Series machine size is 22.312" wide x 14.625" deep x 6.625" high above work plane, exclusive of microscope, or 10.0" high from work plane to scope eyepieces. Weight is 40 lb. uncrated, or 115 lb. accessorized and crated.