

**Model 7KE / 7KEH Series: Manual X-Y-Z, Wedge-Wedge, Ball-Wedge Triple-Convertible Wire Bonders**

*Last revised: 01/16/2015*

*Series Overview*

Application and Function:

Series 7KE models are three-way convertible wire bonders of a gantry design, embodied with unique West-Bond three-axes micro-manipulator in which the entire mechanism is arrayed above the work plane, so that it is wide open to accommodate different size and style of work packages. Cross roller bearing guided X, Y, and Z axes are moving orthogonally, with independent pneumatic brakes applied on signal, which significantly aids to obtain consistent operation control at the time of ultrasonic bonding. Dual counterweights balance the pantograph arm and the tool support individually, and they are complemented by an adjustable spring to counterbalance different tool assemblies. Bonding tools are guided manually by the operator using hand/eye reference to bond targets and elevations. The resulting feel and balance are the best of all the model series.

A dual force mechanism, operated pneumatically, acts to change between two pre-set force values, and either high or low force may be programmed for any bond. Radiant tool heat with panel mounted, controlled by constant current.

With simple exchange of clamp assemblies, bond tool, and wire path provided with the software mode will allow quick conversion between conventional 45° wire feed, deep access wire or ribbon, ball bonding, insulated wire and single point tab / lead bonding. All programmed bond variables as well as machine settings for each bond mode are retained in the machines memory.

Programming and Interface:

All machine configuration constants and bond settings are programmable by selector switches on the machine panel, prompted by a series of "screens" displayed on a 4-line 40-character LCD. All programmed values are displayed during bonding. At "home", various options are enabled.

*Definitions of Models of this Series*

- |              |  |
|--------------|--|
| <b>7KE</b>   | <b>Low Frequency (63kHz) Wedge-Wedge and Ball-Wedge Bonding Machine come with Standard -79 Adjustable Height Working Platform.</b>   |
| <b>7KEX</b>  | <b>Low Frequency (63kHz) Wedge-Wedge and Ball-Wedge Bonding Machine specified as Model 7KE without Base or Working Platform.</b>     |
| <b>7KEH</b>  | <b>High Frequency (110kHz) Wedge-Wedge and Ball-Wedge Bonding Machine come with Standard -79 Adjustable Height Working Platform.</b> |
| <b>7KEHX</b> | <b>High Frequency (110kHz) Wedge-Wedge and Ball-Wedge Bonding Machine specified as Model 7KE without Base or Working Platform.</b>   |

## Mechanical

Ultrasonics:	
Frequency	63 kHz (Model 7KE Series), 110kHz (Model 7KEH Series)
Time	up to 999 ms; programmable
Power	Low Power:2.5 Watts; High Power 4 Watts; programmable
Bond Force:	10 – 250 grams; (High / Low programmable)
Bond Tool:	
Diameter	1/16"
Length	0.625" capillary, 0.750" 45 & 90 degree wedge (Model 7KE Series) 0.750" capillary, 0.828" 45 & 90 degree wedge (Model 7KEH Series)
Tool Heat:	Adjustable radiant heater
Wire Clamps:	
Actuation	Air opened / spring closed
Adjustment	X/Y/Z position; clamp force (through change of spring); opening gap
Bond Wire:	
Size	Au / Al: 0.7 to 3 mil Ribbon: 0.5x2 to 1x10 mil Au Ball Bonding: 0.7 to 2 mil Cu Ball Bonding: 0.7 to 1.5 mil (Special Wire Clamp Assemblies required for wire size above 2 mil or ribbon)
Spool	1/2" diameter Standard, 2" Optional
X/Y/Z Manipulator:	
X axis	linear motion; 8 : 1 reduction; 0.625" travel
Y axis	linear motion; 8 : 1 reduction; 0.625" travel
Z axis	linear motion; 5 : 1 reduction; 0.688" travel
Z encoder	0.001" resolution
Brakes	X, Y & Z axes
Balance	Counterweighted & sprung; biased away from work
Work Elevation:	5.00" nominal above tabletop, actual work elevation vary with different tool configurations and work holder combination

## *Electrical Software and Hardware*

Process Control:	West-Bond Part No. 8100 CPU w/ Motorola 68000 microprocessor, 512 KB of Battery Back-up RAM
Program Buffers:	30 individual buffers of bond settings for a wire type can be entered and selected during bonding by a selector switch. Each wire type can have approximately 21 stitch bonds, each with its own settings of ultrasonic power and time. All programmed values are displayed during bonding.
Display:	4-line, 40-character LCD
Z encoder:	A high-resolution optical encoder is fitted to the Z-axis to provide position measurement of each bond elevation and then to initiate clamp re-closing to control wire loop arch consistency. This encoder enables a second function unique to West-Bond's "E" Series: Upon touchdown, contact is sensed by opening of firing switch contacts but initiation of ultrasonic energy, and the setting of the axis brakes, is withheld until the control is moved downward an additional amount sufficient to follow the deformation of the wire during bonding.

## *ESD Protection*

Protection against Electrostatic Discharge is implemented by finishing exposed tool assemblies and other moving parts by Electroless Nickel plating, which is conductive; and all exposed painted parts with a powder-coated paint that is dissipative (1 - 10 M $\Omega$ ).

## *Machine Configuration*

Microscope:	Olympus SZ51-60E or Nikon SMZ660 (recommended; not included)
Illumination:	"Luxuray" #10265.00 or #10265.01 (recommended; not included)
Bond Tool:	(1) 1 mil, capillary, (1) 1 mil, 45 degree wedge & (1) 1 mil, 90 degree wedge tool (included)
Work Holder:	Workholders are not included, and are priced separately. A large number of previously designed special work holders are available. Those with Status of <i>Current</i> can be selected for delivery in the same time span as the machine, while those of Status <i>Available Not Stocked</i> must be ordered separately. Workholders for new work pieces requiring custom design and fabrication will be quoted upon receipt of drawings and samples: These must be ordered on separate purchase orders.
Temperature Controller:	West-Bond K~1200D / 1201D (recommended; not included)

## *Options Available for this Series*

- K~1100: Automatic Wire Despooler**  
Pays out bond wire at 1.0 in. /sec. from ½ in to 2 in. wire spool. Maintains constant slack with zero drag. Announces end of wire stock. Required -9263.
- 72E: External View TV Camera**  
Color external view TV camera with magnification adjustment within a range of 30X to 55X. Flat screen monitor & power supply included.
- 4141.006: Spool Mount, 2" Nickel Plated, Used on "7KE" series machines (ESD).**  
Universal 2" dia. spool mount, used on "7KE" series machines (ESD) is housed into a Nickel plated aluminum enclosure. The wire is fed through a 6" long Stainless Steel funnel, which serves as a wire guide.
- 9048.004: Assembly, Clamp Blade 45°, 4 Mil Wire, Models "D", "E"**  
45° Feed Clamp Blade Assembly to hold 2 to 3 mil wires.
- 9049.003: Assembly, Clamp Blade 90° 1/2-1Mil X 1-5 Mil Wide Ribbon, Model "D", "E"**  
90° Vertical Feed Clamp Blade Assembly to hold ½ to 1 x 1 to 5 mil ribbon.
- 9049.004: Assembly, Clamp Blade 90°, 1/2-1Mil X 6-10 Mil Wide Ribbon, Model "D", "E"**  
90° Vertical Feed Clamp Blade Assembly to hold ½ to 1 x 6 to 10 mil ribbon.
- 9228: 20" x 20" Platform with extended manipulator arm. Model 7400E Series**  
Extra-large 20" x 20" Work Platform Assembly with extended manipulator arm.
- 9263: Conversion Kit, Wire Despooler Stand for Model 7KE Series used with K~1100**  
Replacement covers to support the K~1100 and give access for the wire from the top of the machine to the tool head.
- 10600.xx: Assembly, Machine Spacer Block**  
Spacer block kit for shimming machine up to specific height requirements. Check for different height specification available.
- 11067: Thin Clamps Assembly, 45° Guide, Model "E"**  
45° Feed Clamp Blade Assembly with exceptional back and side clearance to hold 1 to 1.5 mil wires.
- 11630.03: Adapter Kit, Inert Atmosphere for Cu Ball Bonding , Model 7KE**  
Attachment to provide Inert Atmosphere to protect the Cu Ball formation from oxidation.

### *Services Required*

Compressed Air: 50 psi; clean dry air  
Regulating valve & pressure gauge provided. Connection is via 1/4-inch tubing.

Vacuum: 22 in/Hg min. (Required if equipped with Vacuum Clamping Workholder)

Electrical: 50-60 Hz, single-phase, either 115 VAC or 230 VAC; selected automatically. A fuse and three-prong power cord connector is provided for 115 VAC: For 230 VAC, these must be changed to conform to local requirements.

### *Weights & Dimensions*

Uncrated: 60 lbs; w/o platform

Crated: 140 lbs; w/ accessories

Overall  
Dimensions:

Width	24.22"
Depth	23.03"
Height	11.63" w/o microscope

*Dimensional Drawings*

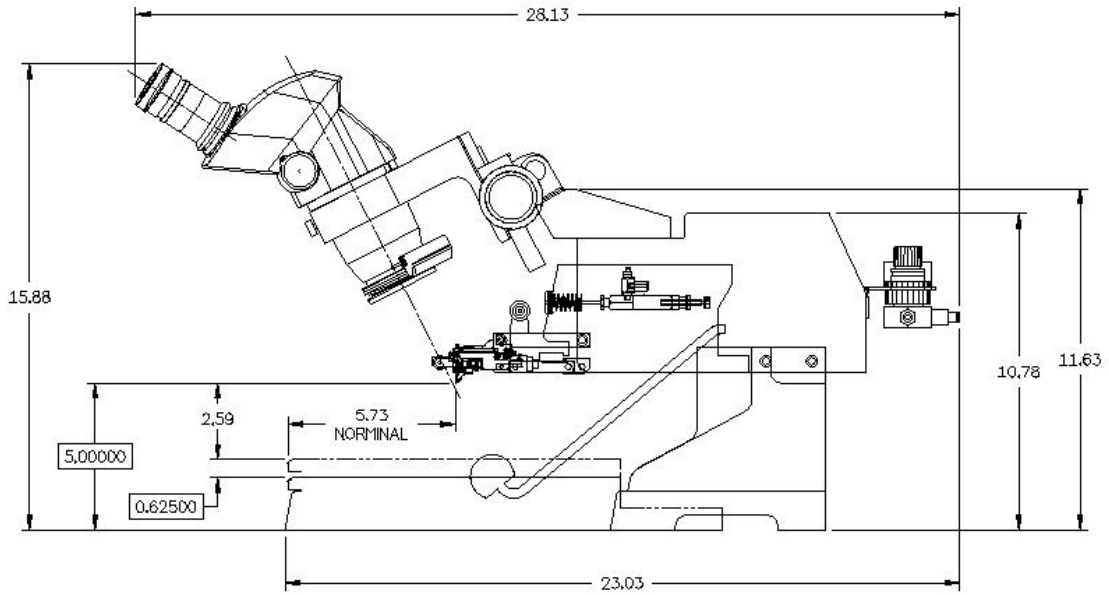

**SIDE VIEW  
WEST.BOND MODEL 7KE WIRE BONDER**

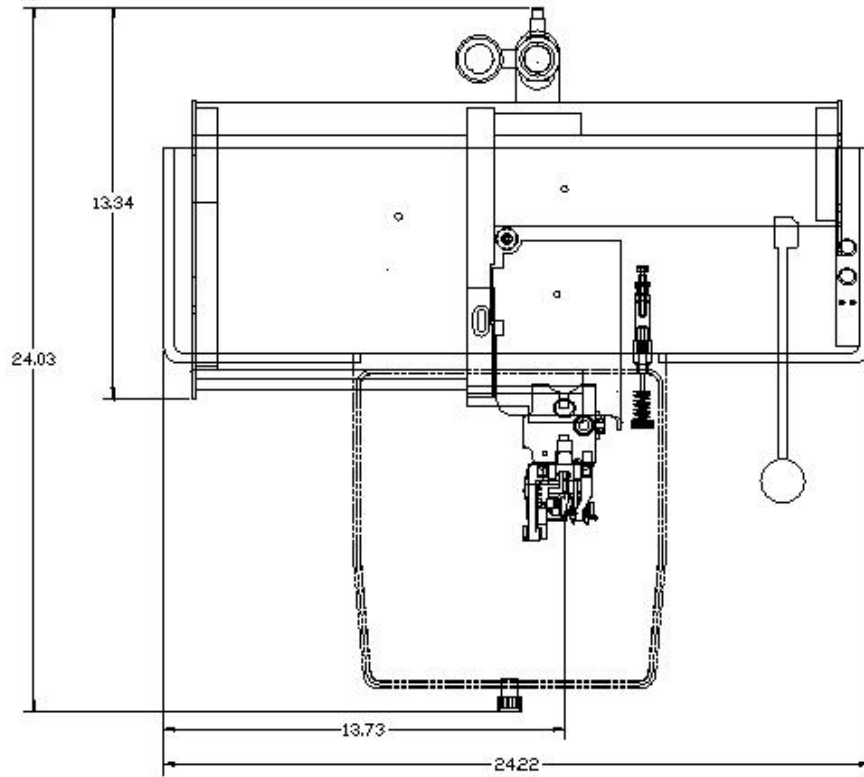

**TOP VIEW  
WEST.BOND MODEL 7KE WIRE BONDER**